



**ECO
LIGHT**
INDUSTRIAL LED

**LED
INDUSTRIAL
FLOOD
LIGHT**

LEDIFL19-160AC

ROBUST INDUSTRIAL LED FLOOD LIGHTS – 160W

The LEDIFL19-160AC fitting is a true industrial grade LED solution.

This is a IP65 rated fitting that includes LM6 aluminium housing and dual layer anti-corrosion powder coat finish it can be relied upon in the harshest of conditions.

This also comes with an anti-glare tempered glass frosted lens and has fantastic light output. This is ideal for a number of different applications including floodlighting, high bay and with the narrow beam angle it makes for the ideal spotlight and tower lighting applications. The bracket includes an easy to use adjustable pivot to enable very precise angle placement



TECHNICAL SPECIFICATIONS

Fixture/Part No.	LEDIFL19N-160AC LEDIFL19W-160AC
Total Power	160W
LED Power	140W
LED Lumens	13,600lm
Fixture Lumens	12,800lm
LED Lighting Efficiency	>90%
Colour Temperature	5700K
Colour Rendering (Ra)	>70
IP Rating	IP65
Life Span	50,000hrs
Eco-friendly	No UV, IR, Lead or Mercury
Operating Temperature	-40°C to 50°C
Weight	12.40kg
Beam Angle	(19N) Narrow Angle: 15.1° (19W) Wide Angle: 80.1°
Size	Diameter 460mm, Height 278mm
Dimmable	Yes
Power Factor	>0.95
Input Voltage Range	86-230V AC
Power Cable	3 core, 1.5m length
Powder Coating	Anti-corrosion Grey
Housing Construction	Cast Aluminium, Tempered Glass
Aluminium Properties	LM6 - Si: 13%, Cu: 0.6%, Mn: 0.6%, Fe: 1.2%, Zn: 0.3%, Al: 84.3%
Bracket	Adjustable Aluminium with Black Powder Coating



**Adjustable pivot for precise
angle placement**

 **ECO
LIGHT**
www.ecolight.co.nz

PRODUCT IMAGES

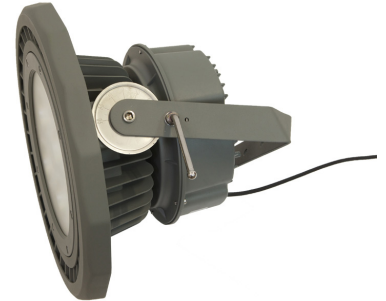

DIMENSIONS

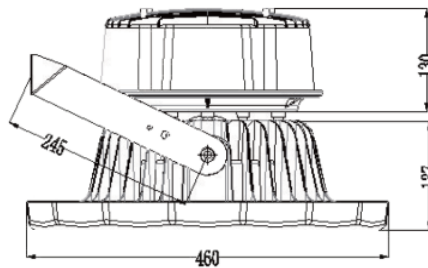
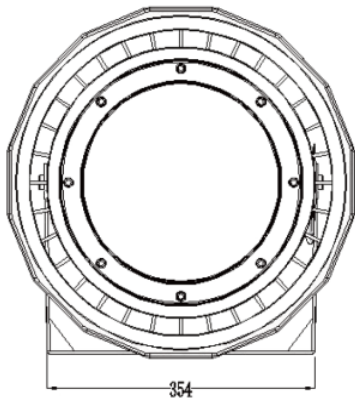

PHOTOMETRICS

Light Distribution

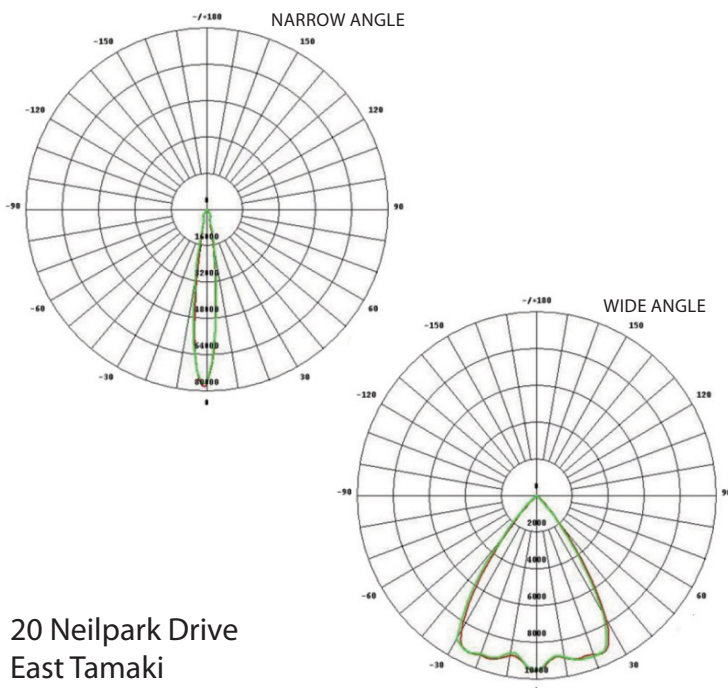

ISO Candela Diagram

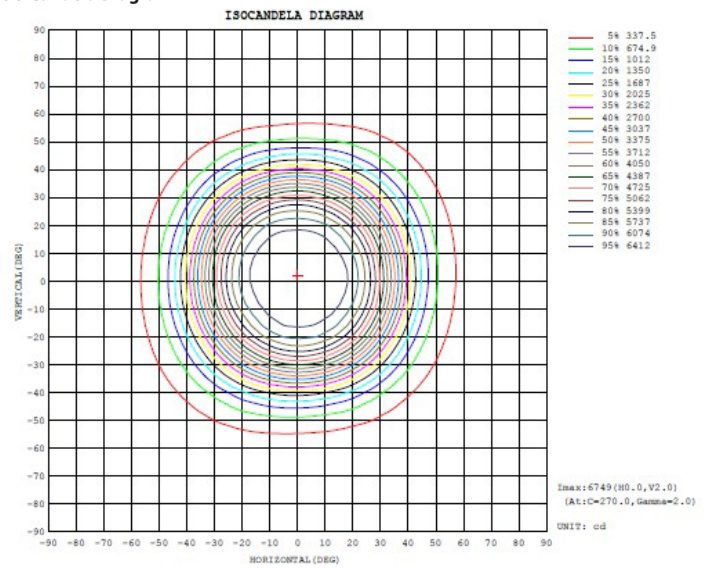

20 Neilpark Drive
East Tamaki
Auckland.
NEW ZEALAND
phone: 64 9 272 5619