

## LEDSOLAR-ST40 • LEDSOLAR-ST40B • LEDSOLAR-ST40P

### SOLAR LED STREET LIGHT KIT – 40W

#### KITSET COMPONENTS

- TNL0729-40DC24
- 250W solar panel
- Battery pillar box
- 2 x 90Ah deep-cycle battery
- 2 x mini-blade fuse holders 32V/30A with fuses
- 12m of 4mm<sup>2</sup> solar twin-core cable
- 12m of 2.5mm<sup>2</sup> twin-core cable
- 10A solar controller

#### APPLICATIONS

Perfect for locations where mains power is not currently available, farm implement sheds, pump stations, Car parks, Workshop yards etc.



#### TECHNICAL SPECIFICATIONS

Fixture/Part No.	TNL0729-40DC24
Power	40W
Lumens	4050lm
Supply Voltage	24 V DC
Power Supply Efficiency	>90%
Power Factor	>0.98
LED Lighting Efficiency	90-110lm/W
Luminaire Efficiency	>90%
Colour Rendering Index	Ra>75
IP Rating	IP65
Life Span	>50,000hrs
Eco-friendly	No UV, IR, Lead or Mercury
Materials	LM06 equivalent Aluminium
Weight (Light only)	4kg
Dimensions	500x278x122mm

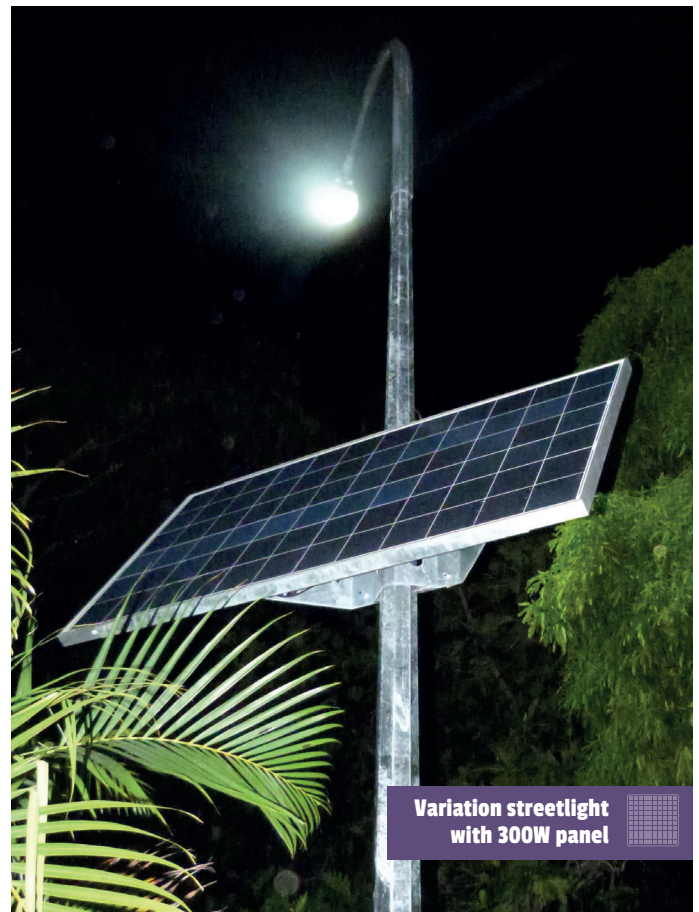

Variation streetlight with 300W panel

**KITSET COMPONENTS**

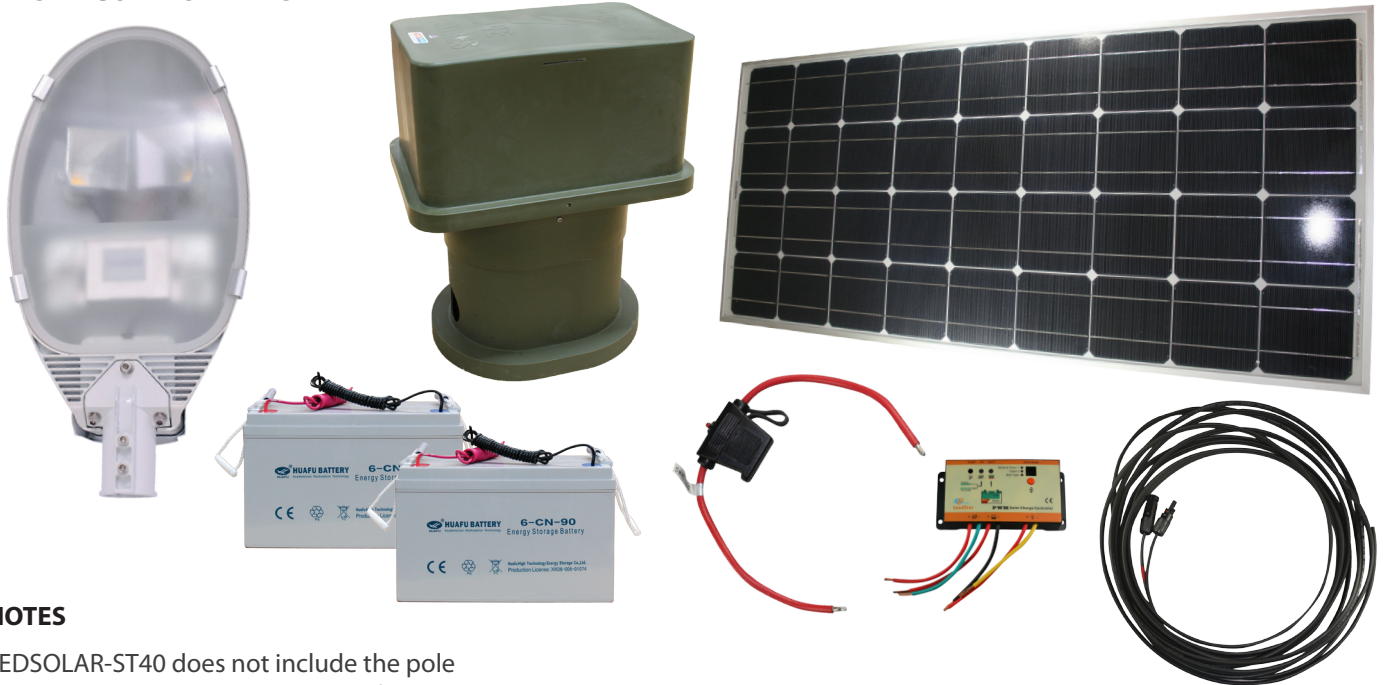

**NOTES**

LEDSOLAR-ST40 does not include the pole  
LEDSOLAR-ST40B includes bracket for solar panel\*  
LEDSOLAR-ST40P includes the pole\*

\*Contact us for more information regarding this

**ISOLUX PLOT**

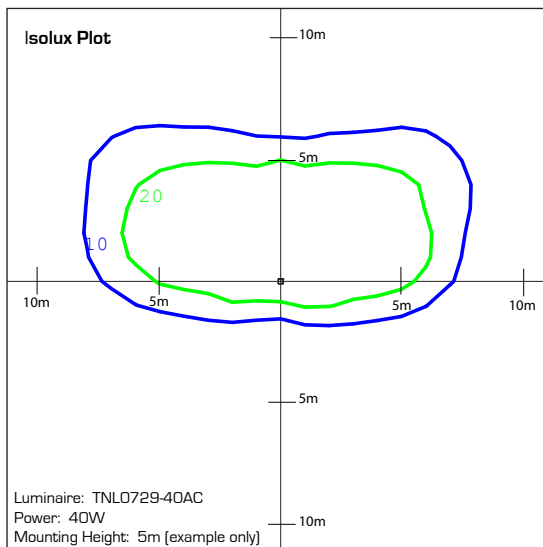

**DIMENSIONS**

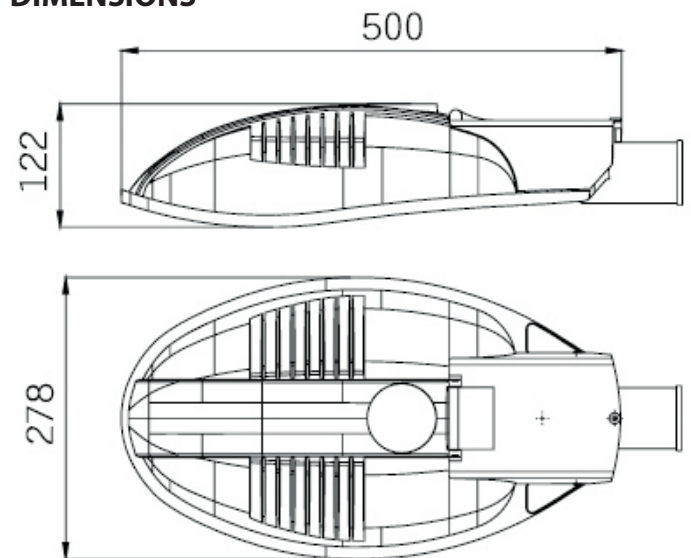

20 Neilpark Drive  
East Tamaki  
Auckland.  
NEW ZEALAND  
phone: 64 9 272 5619