

## LEDUV1500-39AC • LEDUV1500-40SEN • LEDUV1500-41BATT

### LED COMMERCIAL BATTEN LIGHTS

This attractive LED luminaire is designed specifically to replace traditional 5 ft fluorescent fixtures for most areas, including carparking, walkways and under verandah areas.

The benefits of this model are that it has an option for onboard daylight sensor and a microwave sensor for motion detection. In addition, this model also has the ability to run at dim state until motion is detected, optimising lighting & power output to a need only requirement.

This luminaire is also capable of working in conjunction with a row of lights (master & slave) so that only the sensors at both ends of a carpark/ walkway area function.



**Sensor**

### TECHNICAL SPECIFICATIONS

Fixture/Part No.	LEDUV1500-39AC LEDUV1500-40SEN LEDUV1500-41BATT*
Total Power	39W, 40W & 41W
Fixture Lumens	3900
LED Lighting Efficiency	100lm/W
Colour Temperature	5000K
Colour Rendering(Ra)	>80
IP Rating	IP65
Life Span	40,000 hours**, L7 at 40°C
Operation Temperature	-20°C to 50°C
Construction	Aluminium Housing
Impact Rating	IK10
Weight	3.5kg, 3.8kg, 4.2kg
Beam Angle	120°
Suggested Working height	Max.12M
Size	1595 x 134 x 85mm 1692 x 134 x 85mm 1692 x 134 x 85mm
Dimmable	Yes
Power factor	>0.9
Input Voltage Range	220-240V

### IDEAL FOR:

- Parking Buildings
- Warehousing
- Office Buildings
- Schools
- Retail
- Anywhere that twin fluorescent fittings are installed

CAT NO.	Back Up Battery	Sensor
LEDUV1500-39AC	NO	NO
LEDUV1500-40SEN	NO	YES
LEDUV1500-41BATT	YES	YES

\*LEDUV1500-41BATT is tested to AS2293.3-2005 & ASNZS 605982.22:2005 - suitable for both maintained or non-maintained operation with removal of sensor.

\*\*LM80 report can be supplied upon request

Note: Back Up battery is standard in models with suffix BATT only

### DIMENSIONS

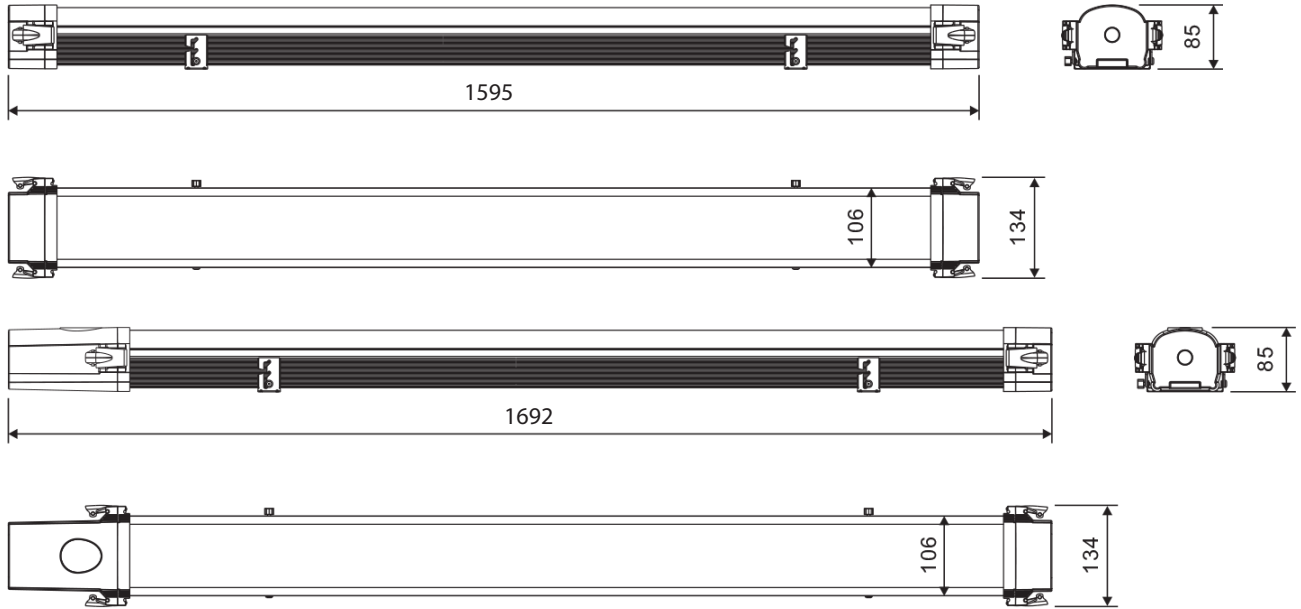

### PHOTOMETRICS

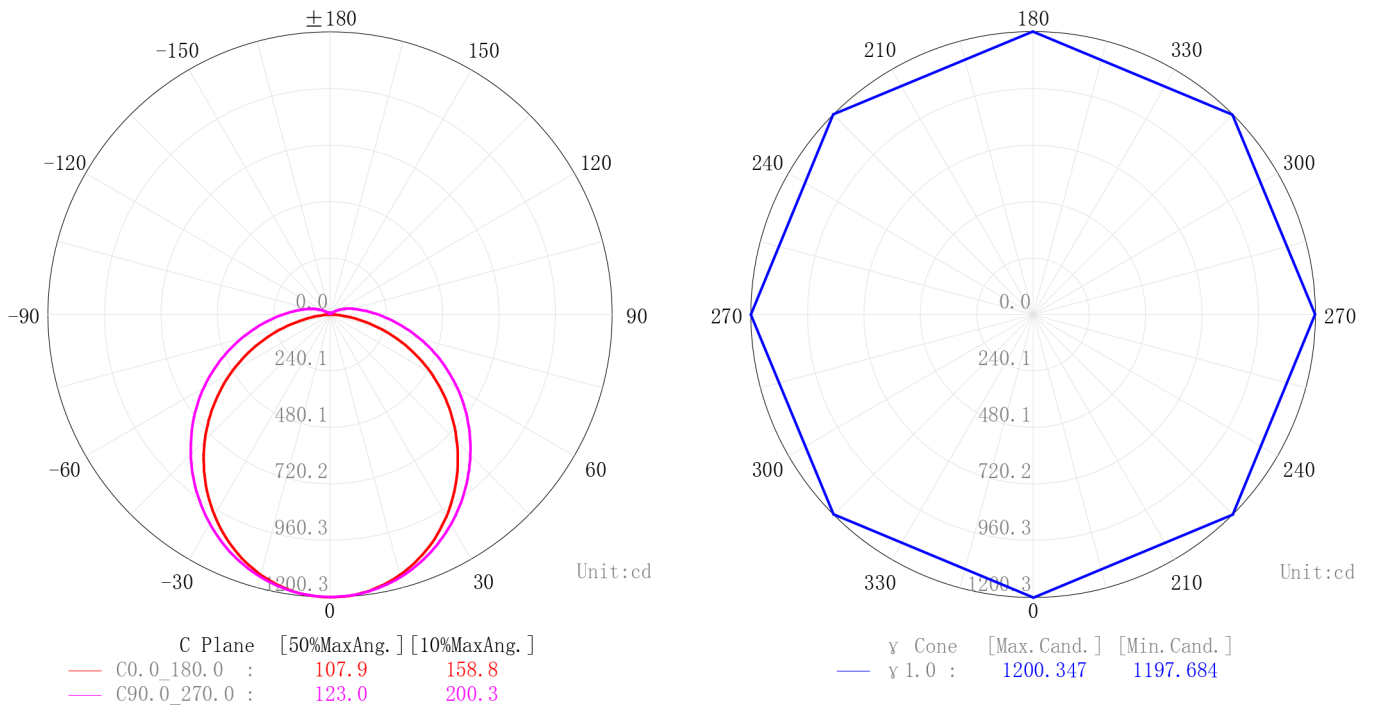

78 Cryers Road  
East Tamaki  
Auckland.  
NEW ZEALAND  
phone: 64 9 272 5619

## MOUNTING OPTIONS

Surface

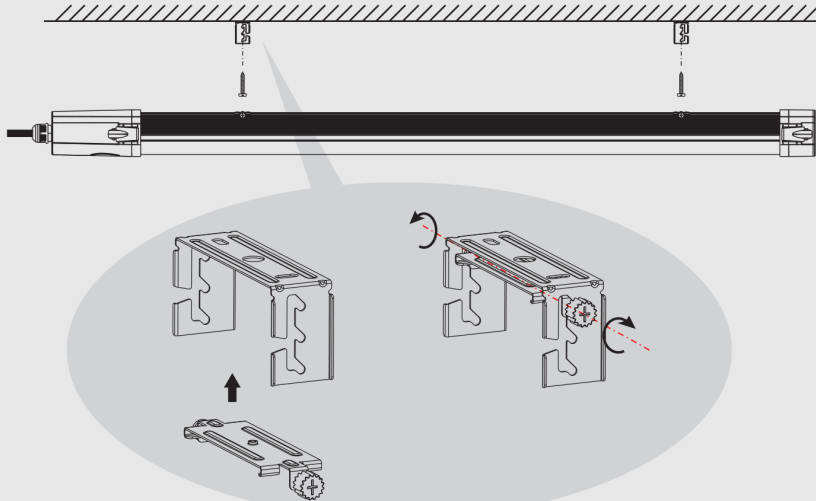

Pendant

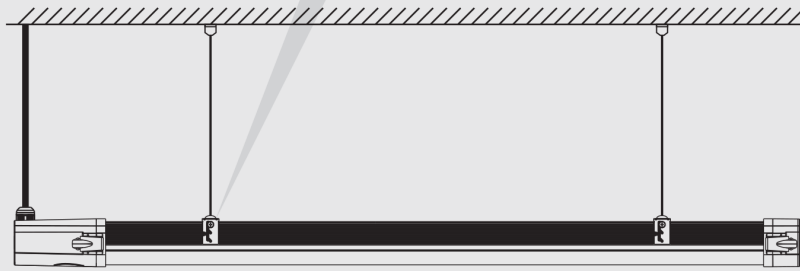

## SENSOR OPTIONS

Master/Slave Function

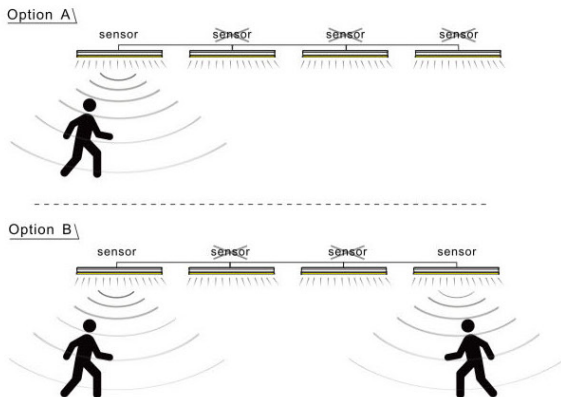

Hi-low Light Function

Option 1: Normal sensor light  
Option 2: Hi-low light operated by sensor

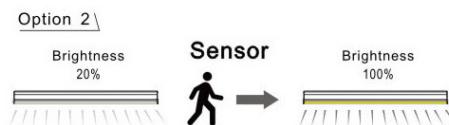
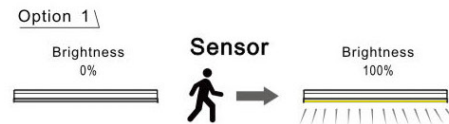

78 Cryers Road  
East Tamaki  
Auckland.  
NEW ZEALAND  
phone: 64 9 272 5619