

WARRIOR SPI-FL24 LED Industrial Floodlight Standard and Emergency Variants

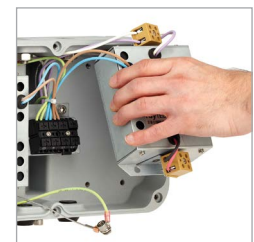

- Zone 1 & 2 variants also available
- Ultra long life LED
- High lumen output LED
- Easy installation, maintenance and inspection
- Wide operating temperature range -50° to +55°C
- VARIO lens technology – easy modification of beam patterns
- Integral photocell (optional)
- Clear external tear off strips on outer optics available
- 5 year warranty
- IR variants available
- Intelligent Emergency battery back-up (optional)

The SPARTAN Flood range is designed specifically for industrial applications which require high performance, high reliability, White-Light illumination. Available in both standard and emergency versions and using Raytec's field-proven, long-life LED technology, SPARTAN floodlights are suitable for a wide range of industrial applications. SPARTAN Flood has been designed with maintenance in mind. A unique modular design allows key components to be easily accessed and serviced if required, making inspection and maintenance quicker and easier. It also allows for the most flexible installation. The PSU chassis can be removed and located remotely at ground level for areas with difficult access, while standard units can also be upgraded to an intelligent emergency fitting at any time with an additional battery back-up module. All emergency units come with intelligent battery management to proactively monitor and maintain the overall health of your luminaire.

SPARTAN Flood is available in a range of different beam patterns, both circular and elliptical, with revolutionary interchangeable VARIO lens inserts which can be easily altered on-site delivering the ultimate flexibility to specifiers, distributors and end users. SPARTAN uses **COOLEXTRUDE™** thermal management technology, ensuring a much cooler LED operating temperature and up to 60% better heat dissipation compared to traditional lighting solutions, allowing the product to operate for > 10 years while still delivering a high lumen output of up to 9,300 lumens.

Product Dimensions

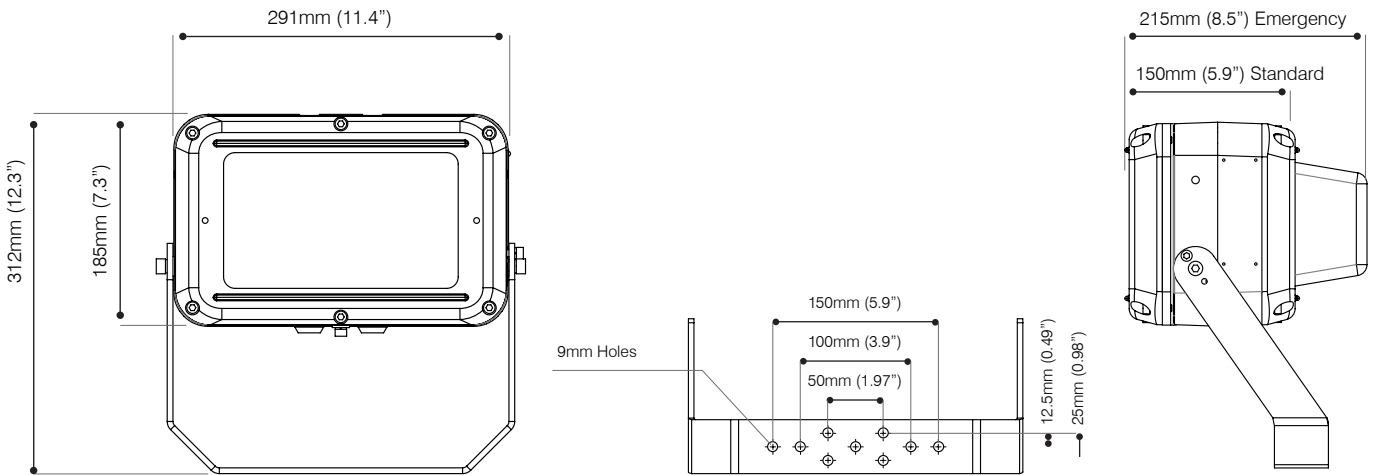

Features	Benefits
Ultra-Powerful	High lumen output - up to 9,300 lumens Latest high power LED technology
Ultra-Flexible	Beam patterns from 10° to 120° both circular and elliptical Operating temperature range of -50°C to + 55°C for even the most challenging conditions (-20°C emergency variants) Models incorporating Vario Technology allow for easy modification of beam pattern
Ultra-Reliable	Industry leading 5 year warranty Designed and manufactured in the UK to the highest standards including both ISO9001 & ISO14001 Advanced electronics protected by vibration resistant and water proof potting compound Intelligent emergency with automatic self-testing
Ultra-Modular	Both the LED and PSU modules are easily accessible for maintenance and inspection Removable PSU housing allows power supply to be fitted remotely
Ultra-Efficient	COOLEXTRUDE™ thermal management delivers class leading energy efficiency Significant running and maintenance savings compared to traditional lighting technologies SMART access wiring system for safe and efficient installation, set-up and ongoing inspection
Ultra-Support	Photometric files available (.ies & .ldt) Full Lighting Design Service Site specific Energy and Cost Saving Report available

5 YEAR WARRANTY

All Raytec luminaires are provided with an industry leading 5 year warranty and have an expected useful life in excess of 10 years



Technical Specifications

Electrical

Input:	110-254V 50/60Hz AC only Low voltage: 18-48V AC and 18-69V DC Extra low voltage: 12V AC/DC
Power:	Standard - 68W Emergency - 71W
Termination	Incoming terminal block suitable for looping 4 core 4mm ² cable
Power Factor:	>0.95
Cable Entries	2xM20 as standard (other entries available upon request), dispatched complete with blanking plugs

Optical

Beam Patterns-circular:	10°x 10° or 30°x 30° or 50°x 50° or 120°x 120° (10 x 10 option can be upgraded to VARIO Technology)
Beam Patterns-elliptical:	35°x 10° or 60°x 25° or 80°x 30° or 120°x 50° (VARIO)
Lumen output on mains:	Up to 9,300 lm – circular beam patterns Up to 9,050 lm – elliptical beam patterns (VARIO)
LED type:	Platinum Elite SMT LEDs
Number of LEDs:	24
CRI	80+
Colour Temperature:	6,000K+

Mechanical/Environmental

Burning position:	Universal
IP rating:	IP66 & IP67
Temperature range:	-50°C to +55°C (lower ambient of -20°C only for emergency variants)
Weight:	Standard - 8kg (17.6lbs) Emergency - 10Kg (22lbs)
Enclosure:	Marine grade aluminium epoxy powder coated, toughened glass, all external fasteners and brackets are marine grade stainless steel
Unit Colour:	Front - White (RAL 9016) Back - Silver (RAL 9006) Emergency cover - Red (RAL 3024)
Installation instructions:	Please contact Raytec for copy
Dimensions:	Standard - 291 x 312 x 150mm (11.5 x 12.3 x 6") Emergency - 291 x 312 x 215mm (11.5 x 12.3 x 8.5")
Mounting:	U bracket (see dimension drawings on Page 2)

Intelligent Emergency Battery Back-Up

Emergency Duration:	Up to 90mins at 50% power Other options available
Emergency Battery:	Ni/Cd 12V 4.5Ah
Emergency Charge Time:	20 hours

Product Codes - Industrial

Circular beam pattern

Part Codes	Description (T4 variants as standard)
SPI-FL24-W-1010	SPARTAN Industrial Flood, 24 LED, White-Light, 10°x 10° beam
SPI-FL24-W-3030	SPARTAN Industrial Flood, 24 LED, White-Light, 30°x 30° beam
SPI-FL24-W-5050	SPARTAN Industrial Flood, 24 LED, White-Light, 50°x 50° beam
SPI-FL24-W-120120	SPARTAN Industrial Flood, 24 LED, White-Light, 120°x 120° beam

For intelligent emergency versions – add '-EMX50' to the above codes
18-69V variants available, add '-LV' to the above codes
12V variants available, add '-ELV' to the above codes

Elliptical beam pattern

Part Codes	Description (T4 variants as standard)
SPI-FL24-W-3510	SPARTAN Industrial Flood, 24 LED, White-Light, 35°x 10° beam
SPI-FL24-W-6025	SPARTAN Industrial Flood, 24 LED, White-Light, 60°x 25° beam
SPI-FL24-W-8030	SPARTAN Industrial Flood, 24 LED, White-Light, 80°x 30° beam
SPI-FL24-W-12050	SPARTAN Industrial Flood, 24 LED, White-Light, 120°x 50° beam

For intelligent emergency versions – add '-EMX50' to the above codes
18-69V variants available, add '-LV' to the above codes
12V variants available, add '-ELV' to the above codes

Beam patterns - Circular

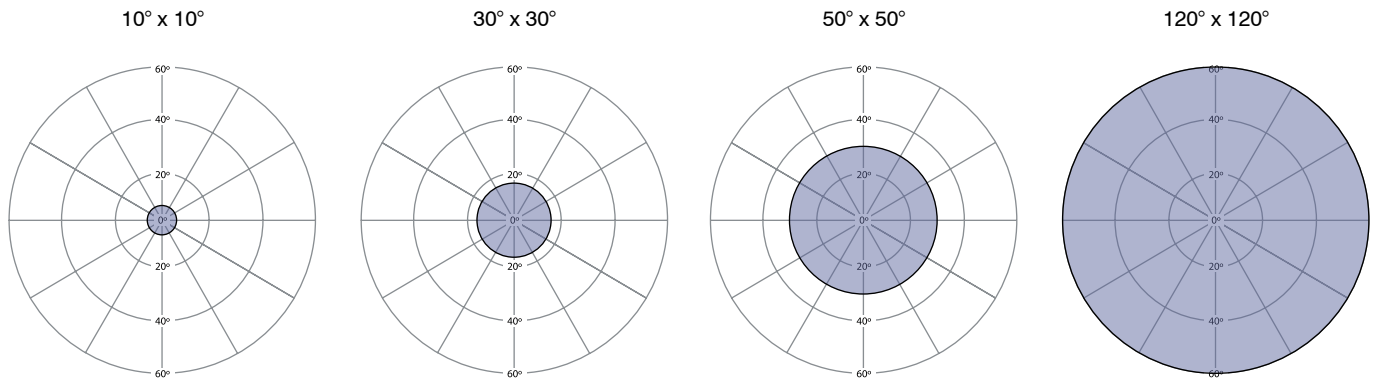

Beam patterns – Elliptical (VARIO)

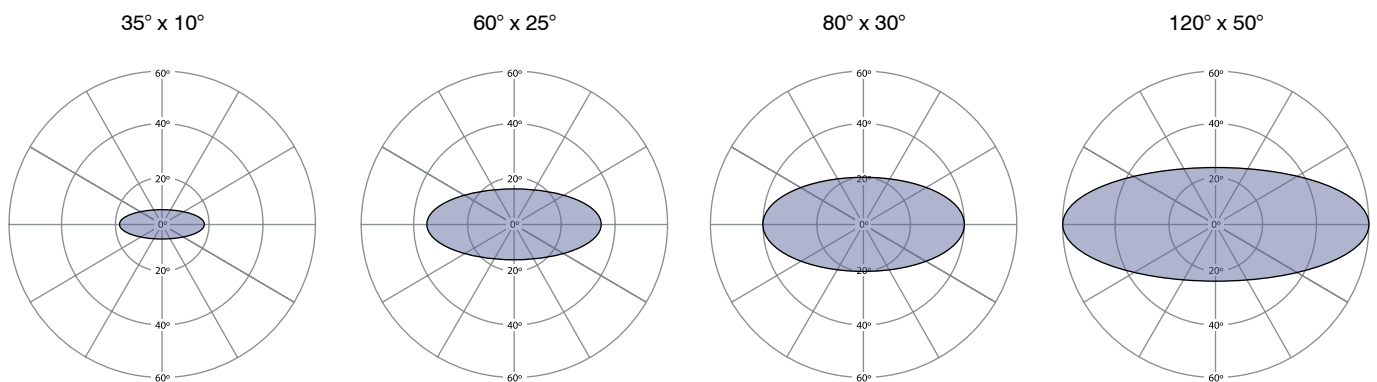

Products in the SPARTAN Flood range

Zone 1, Zone 2, UL/CSA, Industrial
Intelligent Emergency variants also available

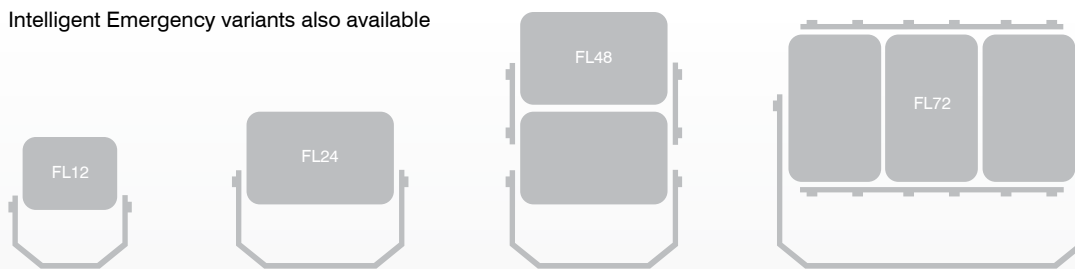

Products in the SPARTAN Family

